

532nm Nd:YAG q-switched picosecond laser MO Microchip laser system



DESCRIPTION

532nm laser is one of the most common lasers used in most fields. It can emit excellent green light. It is based on Nd:YAG crystal. Frequency doubling technology is used in ULaser's 532nm laser. As a perfect picosecond laser, our 532nm laser has version of 300ps.

Like our all lasers, 532nm laser has very pure pulsed output. Thus, stability and high quality have become synonymous with our 532nm laser. Good penetrability and strong anti-interference of stray light makes our 532nm laser can adapt most situations.

532nm laser is commonly used in industrial field, like laser engraving and etching to print circuit boards, micro-machining, and so on. Medical field is another common field for 532nm laser. Our 532nm laser is suitable for yag laser eye surgery. Laser ultrasound, laser induced fluorescence, solid state lidar, and et al, are also its competent field.

FEATURES

- Pulse width < 1ns
- The repetition frequency is adjustable from 1 to 200Hz
- The laser energy is adjustable on the machine
- Optical trigger output signal jitter < 100ps
- Fully sealed design, high reliability
- Plug and play, including upper computer software

APPLICATIONS

- Laser engraving
- Laser photoluminescence
- Laser capture micro-cutting
- Raman spectroscopy detection
- Laser induced breakdown spectrum
- Laser remote sensing

OUTLINE SIZE(mm)

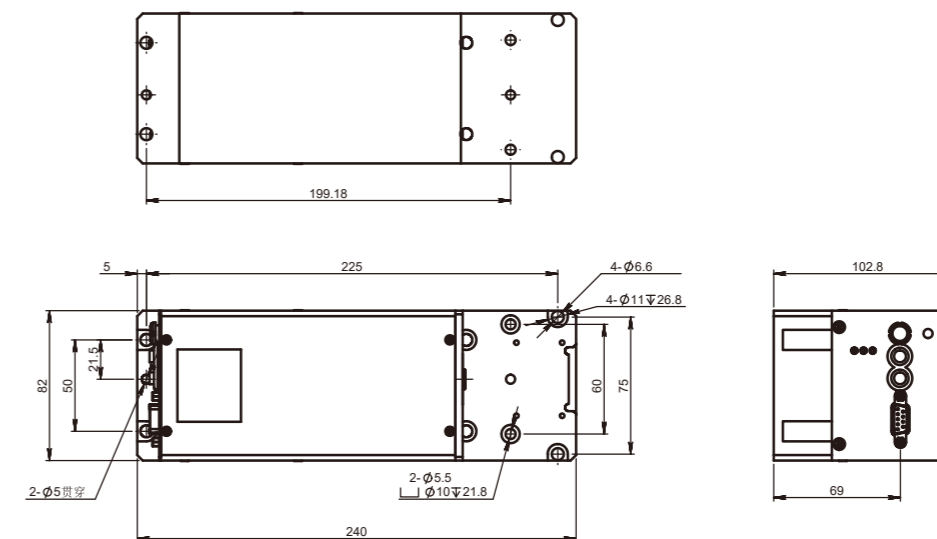

Space output size diagram

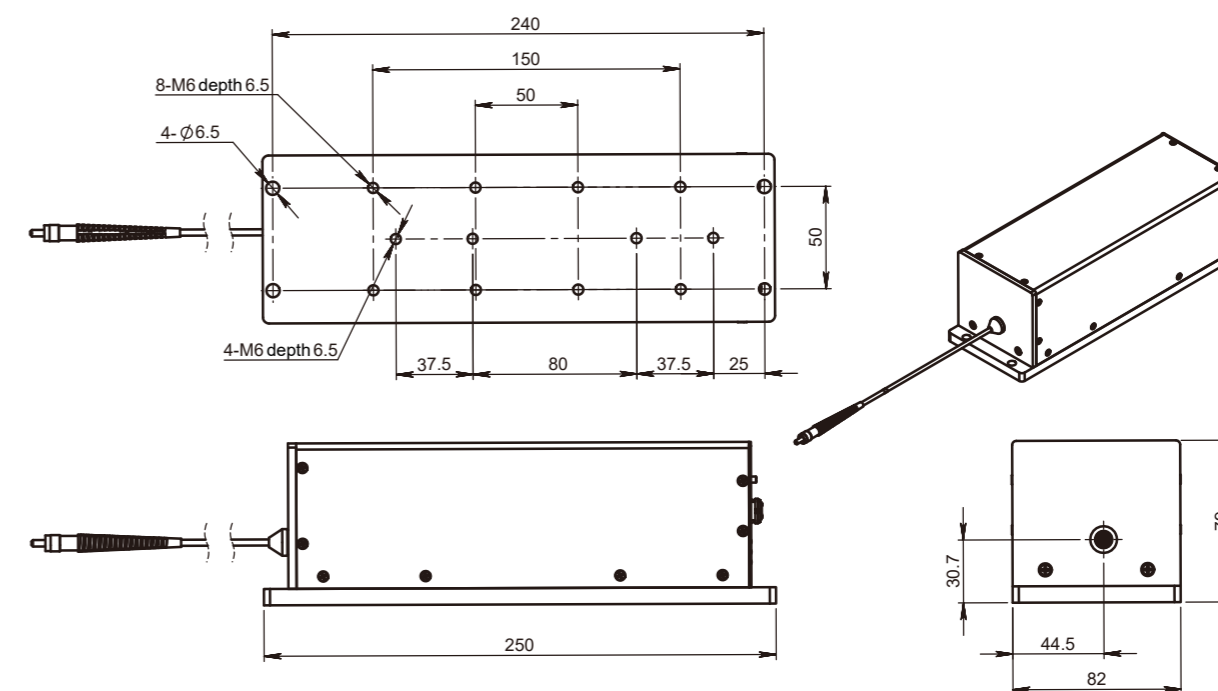
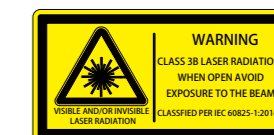
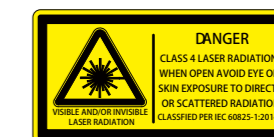

Optical fiber output size diagram

PARAMETERS

Model	UL532-200Hz-30/25μJ-MO003	
Optical parameter	Wavelength(nm)	532
	Repetition frequency (Hz)	1-200
	Maximum output energy of space beam (μJ)	30
	Fiber Coupling Maximum Output Energy (μJ)	25
	Pulse width (ns)	≤1
	Energy Stability(rms)	≤3%
	Energy Regulation Step Accuracy	≤1%
	Beam mode (spatial beam output)	TEM ₀₀
	Full-angle divergence angle Typ. (Mrad) level @1/e ²	≤2
	Vertical @1/e ²	≤2
System parameters	Polarization characteristics	≥100:1
	Fiber parameters (fiber coupled output optional)	200μm/0.22NA
	Power input	24V DC
	Modulation input	TTL0-5V,SMB connector
	Control interface	RS232
	System Peak Power Consumption (W)	< 20
	System Average Power Consumption (W)	< 10
	Laser size (W × H × L, mm)	82×102.8×240(space)/ 82x79x250(optical fiber)
	Working temperature (°C)	15-35
	Storage temperature (°C)	0-60

1. The supported operating frequency is 16~200Hz in continuous mode and burst mode.
2. Fiber core diameter: 200μm.
3. The power supply adapter is shipped with matching power supply, which can support 90~260VAC power supply input.

